



Mugrug by CASEY YORK



#MarcusMugshot

Garden Path

mug rug

MATERIALS:

White: 1 fat quarter or $\frac{1}{4}$ yard for top, backing, and binding

Black: 1 fat eighth for appliqués

Batting: 10" X 10"

Black thread for stitching appliqués

White thread for quilting and binding

$\frac{1}{2}$ " bias tape maker

CUTTING INSTRUCTIONS:

1. From white, cut:

(1) square measuring 8" by 8" for Mug Rug top

(1) square measuring 10" by 10" for the backing

Reserve the remaining fabric for binding

2. From black, cut on the bias:

(8) 1" wide strips (see diagram; each strip should measure approximately 12 $\frac{1}{2}$ " long)

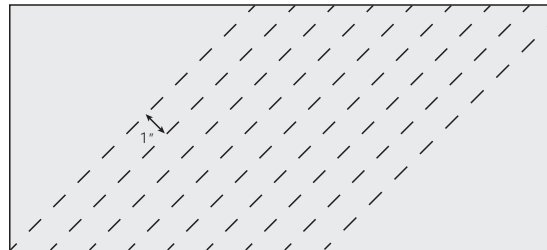

MAKE THE BIAS TAPE STRIPS:

1. Following the manufacturer's instructions, feed (4) bias strips through the $\frac{1}{2}$ " bias tape maker

2. Stitch (2) of the remaining bias strips together on the diagonal to make one 24 $\frac{1}{2}$ " strip; repeat with the remaining (2) bias strips. Feed the resulting 24 $\frac{1}{2}$ " strips through the bias tape maker to form (2) long lengths of bias tape.

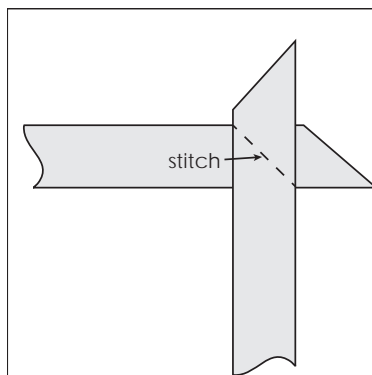

MARK THE APPLIQUÉ PATTERN:

1. Print the Appliqué Template page, checking the 1" square to make sure you have printed it at full scale.
2. Place the Appliqué Template page under the 8" fabric square, centering the design within the 8" square. Use a removable fabric marker to lightly trace the lines of the pattern onto the fabric square (note that bias tape will completely cover the lines, so you will not need to remove them.)

PLACE AND STITCH THE APPLIQUÉS:

1. Carefully center and pin the bias tape over the traced lines in the order described below. Using a straight stitch and matching thread, stitch close to each edge of the bias tape to secure to the background. For curved segments, stitch the inner edge of the curve first; then press the tape using steam to relax the tape before stitching the outer edge of the curve.

Note: The raw ends of the quarter-circles and partial line segments will be caught under overlapping appliqué, but the raw ends of the inner circle and outer square will need to be finished so that they don't fray. To do so, carefully pin the bias strip in place and trim the ends so that they overlap $\frac{1}{2}$ ". Unfold one end and use steam and high heat to fold the raw edge under to make a $\frac{1}{8}$ " hem; refold and press again to create a finished edge. Tuck the remaining raw end into the finished end and pin, then stitch along both edges to secure.

2. Using (2) bias strips, arrange and stitch the four line segments, trimming the strips to size.
3. Using (2) bias strips, arrange and stitch the four quarter-circles. Make sure to stitch the inner edges of the curves first, press, and then stitch the outer edges of the curves.
4. Using (1) of the two long bias strips, arrange and pin the central circle. The outer edges of the circle should cover the raw ends of the four line segments. When you have pinned the circle, finish the raw ends as described above. Stitch the inner edge of the circle, press to relax the bias strip, then stitch the outer edge of the circle.
5. Using the remaining long bias strip, arrange and pin the outer square. The outer edges of the square should cover the raw ends of the four line segments and four quarter-circles. Beginning in the center of one edge, pin the square one side at a time. At each corner, press to miter the bias tape: first fold the tape backwards upon itself and press, then fold the tape 90 degrees to create a 45 degree mitered fold (see diagrams). When you have finished pinning, finish the raw ends as described above. Stitch the inner edge of the tape and then the outer edge to secure.

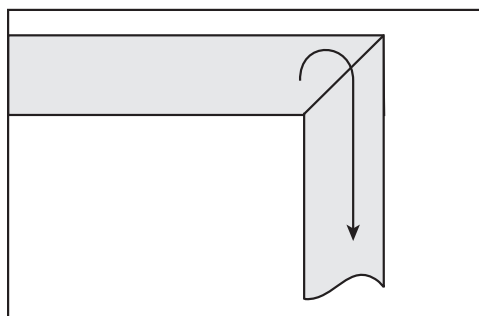
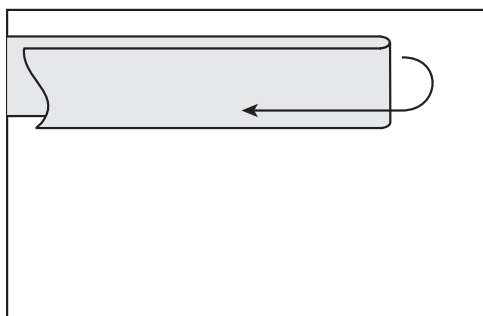

FINISHING:

1. Layer the top, batting, and backing and quilt as desired. Trim to 8" square
2. Using the remaining white fabric, bind using your favorite method.

APPLIQUÉ TEMPLATE

(Check 1" box to ensure template has printed at correct size)

